

Verktyg och teknik för lönsam logistik

Logistic assurance in new car programmes

Johan Rådmark

Director Logistic Development

Volvo Car Corporation

Logistic assurance in new car programmes

From reactive packaging and transport "fixing" to proactive logistic assurance in early project phases

Logistic assurance in new car programmes

Logistic assurance activities



Logistic assurance in new car programmes

Logistic assurance activities



Concept studies

**Industrial structure
Definition**

Landed cost

Supplier choice

Logistic audits

Logistic assurance in new car programmes

Concept studies

**Taking part in early design discussions
ensuring that logistic requirements are considered**

**Participating in make / buy studies in order to make sure
that most cost efficient solutions are chosen from an
holistic point of view**

**Ensure that correct logistic resources are foreseen in the
project**

Logistic assurance in new car programmes

Industrial structure definition

Assuring that we have an industrial structure that supports our Customer Ordered Production concept.

The VCC customer ordered production concept is vital for our overall business result.

Customer Ordered Production

The LTO supply chain

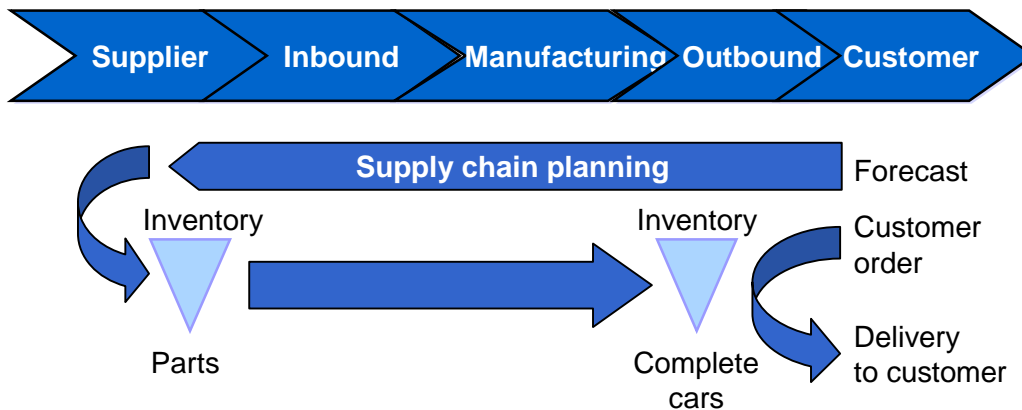

- ▶ Focus on transportation cost
- ▶ Supply chain performance is important

“You can have the cars that we have and you can have them now”

The BTO supply chain

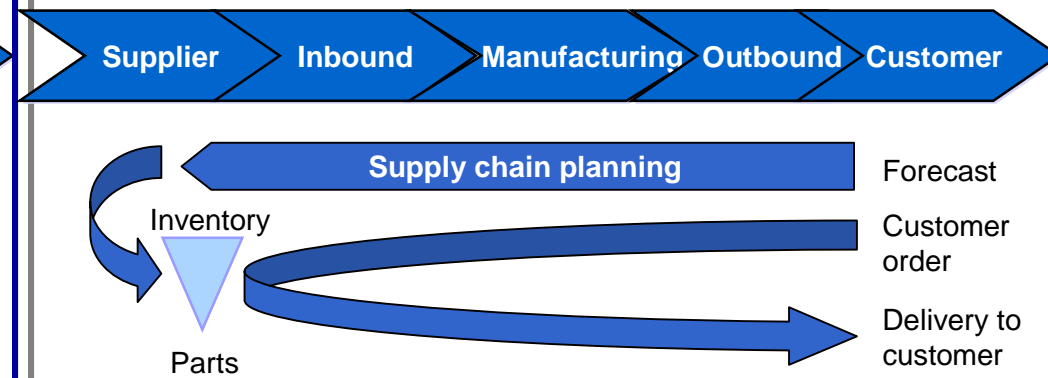

- ▶ Focus on overall supply chain cost
- ▶ Supply chain performance is decisive

“You can have whatever car you want within a short lead time”

Presentation supplier parks VCC

Supplier park VCG

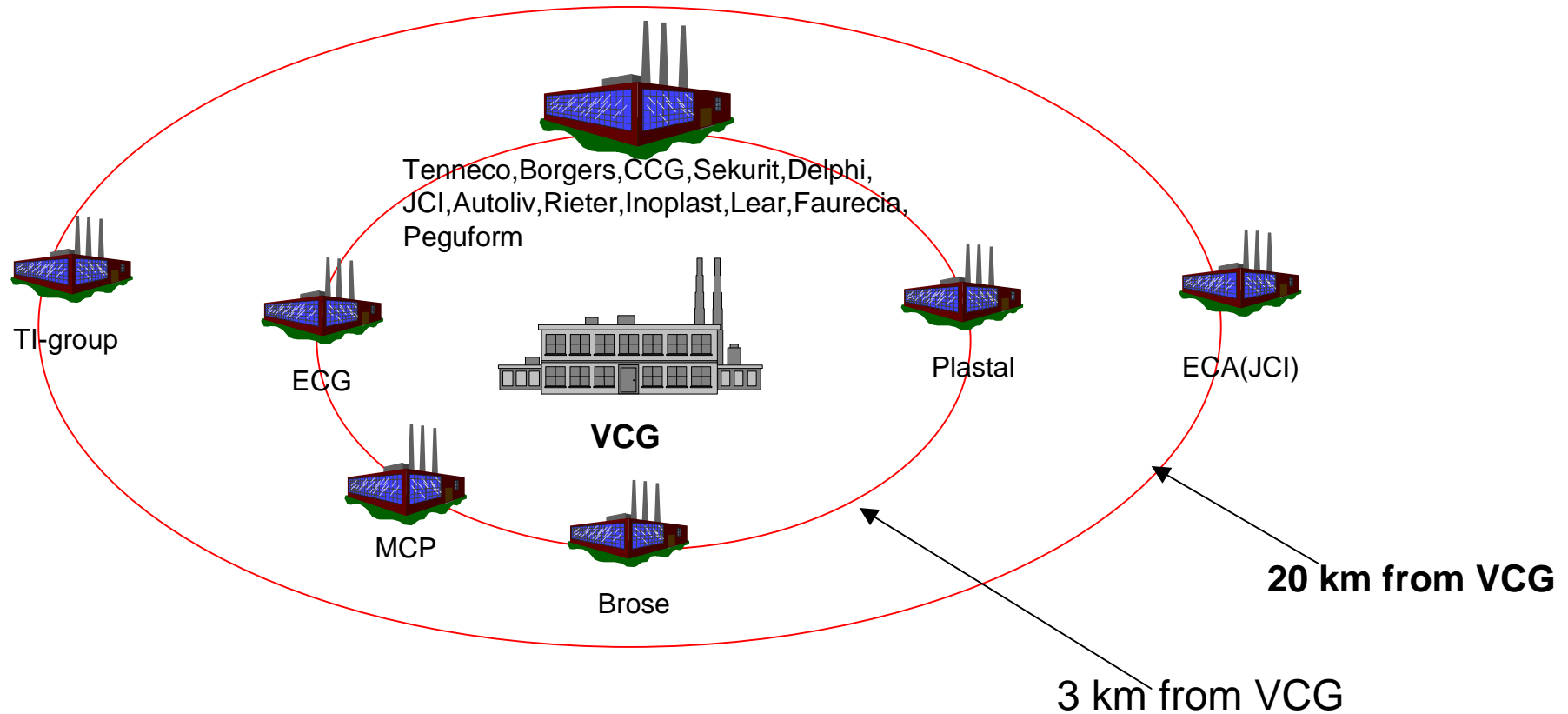

Presentation supplier parks VCC

Supplier park structure VCG(S60/V70,S40/V50)

<u>Supplier</u>	<u>Delivery unit</u>	<u>Car family</u>
Autoliv	Steering wheels,IC,Airbags	P1 & P2
Brose	Door module	P1
Borgers	Parcel shelf	P2
Rieter	Parcel shelf	P1
	Carpets	P1 & P2
Delphi	Cable harnesses	P2
Lear	Cable harnesses	P1
ECA (JCI)	Seats	P1 & P2
Faurecia	Cockpit,Door panels	P1 & P2
	Tunnel console	P1
JCI	Tunnel console	P2
	Head lining	P1 & P2
	Pillar trims	P1
Collins & Aikman	Pillar trims	P2
CCG (Benteler)	Rear axle,front center, wheel corner	P1 & P2
ECG	Power pack	P1 & P2
Sekurit	Glass	P1 & P2
Kautex	Fuel tanks	P1
TI-group	Fuel tanks	P2
Tenneco	Exhaust systems	P1 & P2
MCP	Wheels	P1 & P2
Peguform	Bumpers	P1
Plastal	Bumpers	P2

Logistic assurance in new car programmes



LANDED COST

	Transport	Cost
	Internal handling	“
	Packaging	“
	Administration	“
	Capital	“
	Surfaces	“
+	<hr/>	
=	LOGISTIC COST	
+	PART PRICE	
=	<hr/>	
	LANDED COST	

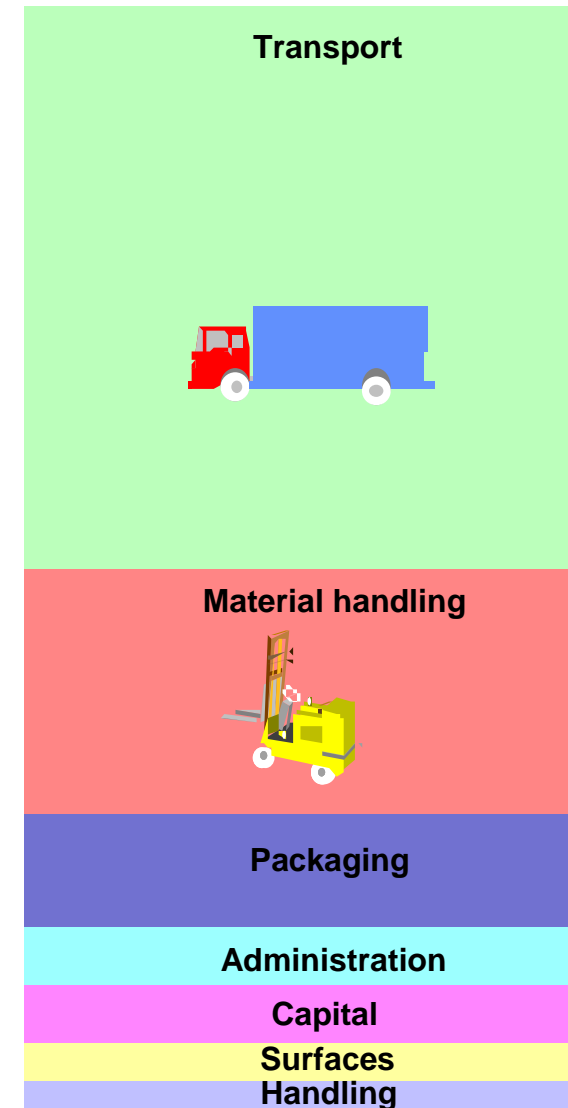

Logistic assurance in new car programmes

MMOG = Global Management Operations Guideline /
Logistics evaluations

Audit that is being performed on all new potential suppliers or suppliers which constantly cause problems to VCC.

Self assesment with verification follow up visit at site if needed.

Logistic assurance in new car programmes

Supplier Choice

The most important thing in a new car project is to select the correct supplier and make sure that we provide the correct prerequisites.

Logistic assurance in new car programmes

Logistic assurance activities

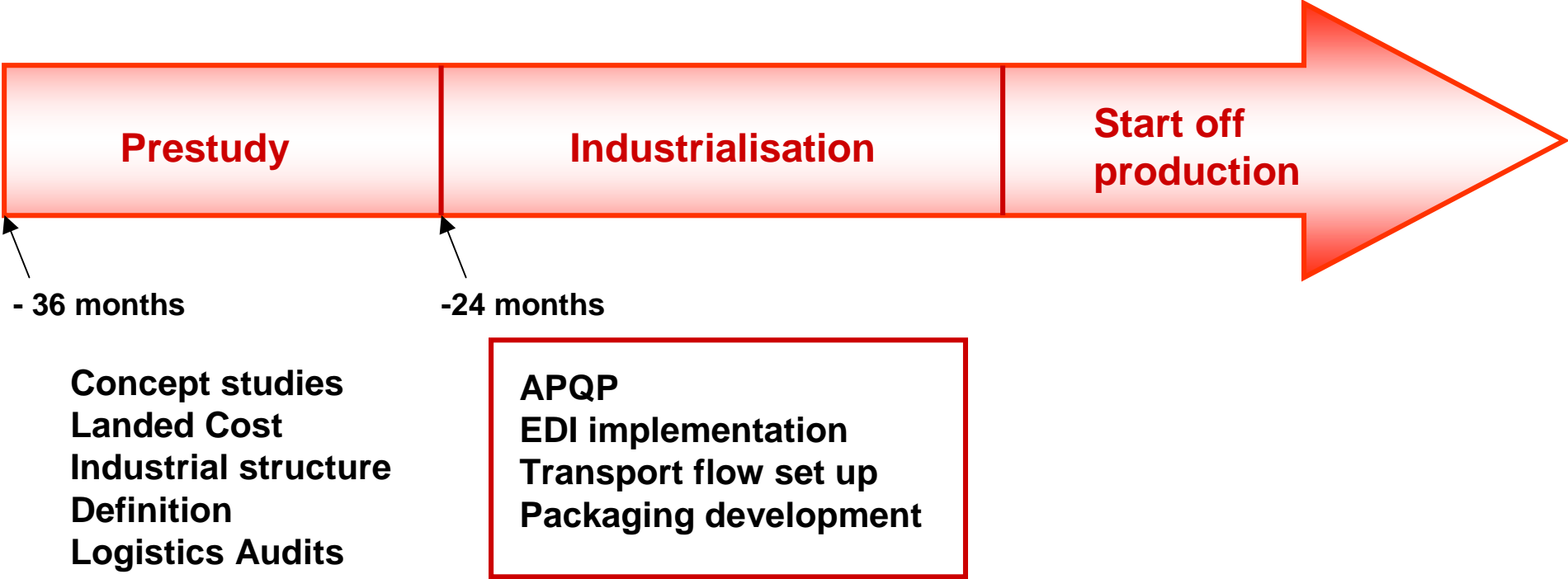

Logistic assurance in new car programmes

Advanced Quality Program Planning

Since 2003 the VCC APQP also contains 47 questions that are mandatory for all suppliers in a car project to answer.

Based on these answers and the results from the MMOG audit we can prioritise which suppliers needs extra focus during the industrialisation phase.

Logistic assurance in new car programmes

Logistic Assurance within APQP

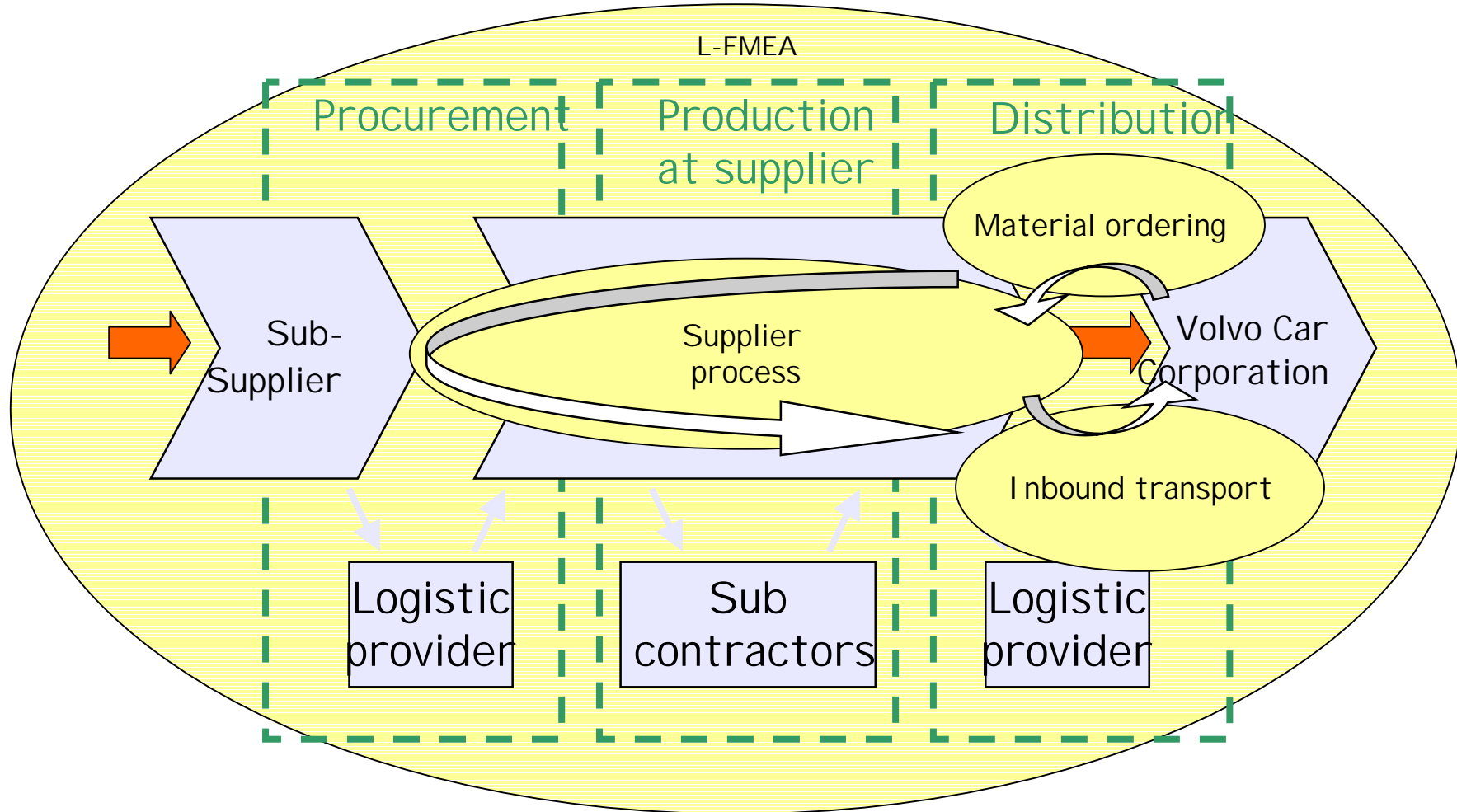

FLEXIBILITY CHIMNEY MODEL

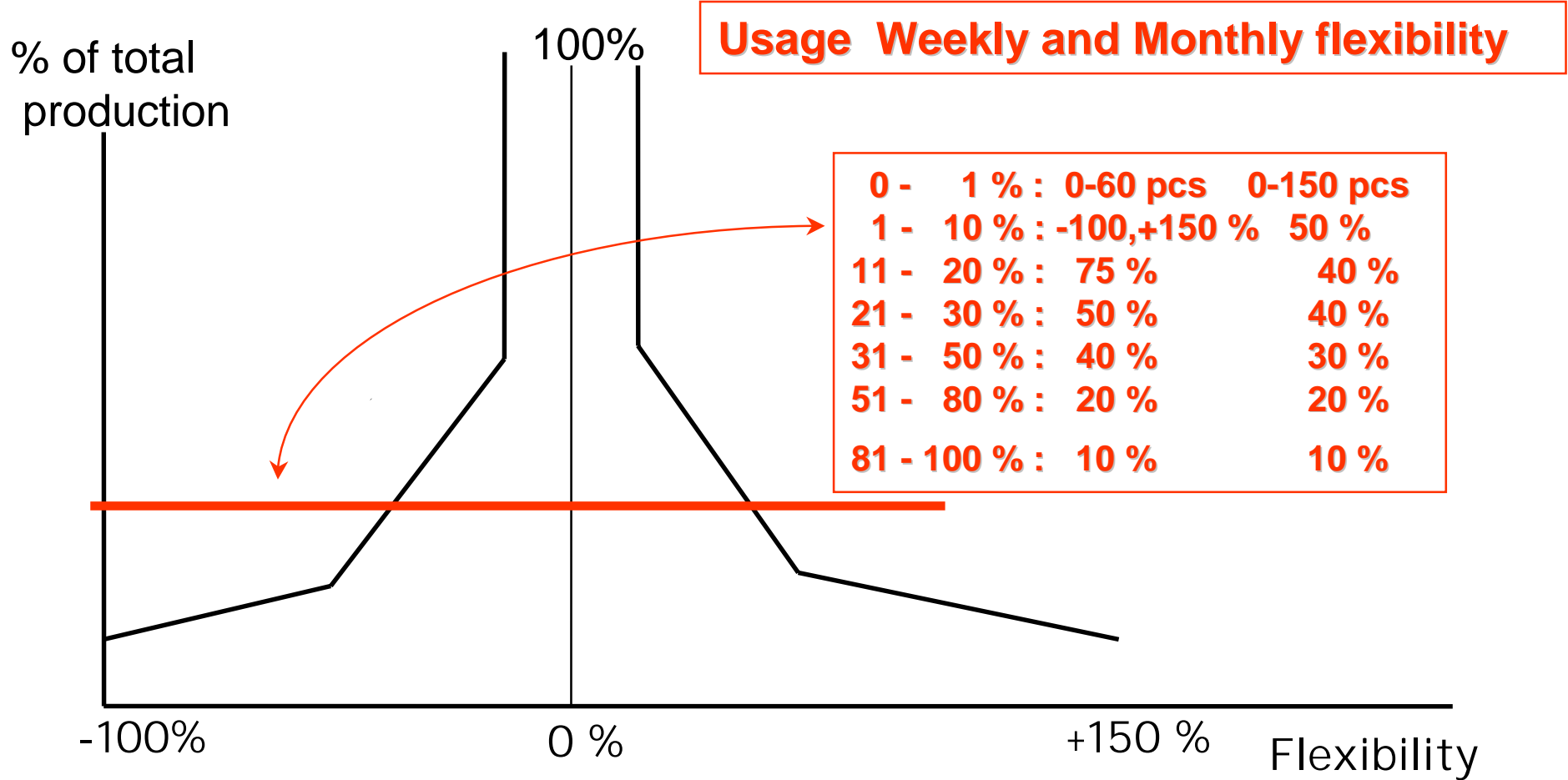

Logistic assurance in new car programmes

Volvo Cars EDI Demands

- 100% usage of EDI without a manual interference, the business must include the following functionality's according to Volvo's profile of the Odette subset of EDIFACT.
- DELINS, Delivery schedules message.
- Calloff, based on DELINS
- SYNCRO only sequence suppliers.
- AVIEXP, Advanced shipping note.
- OTL, Odette transport label.
- INVOIC, Self-billing message. Based on D96A
- ENGDAT, Engineering model exchange with a two way capacity.

Logistic assurance in new car programmes

Transport flow set up

Optimise transport cost and frequency.
Minimise environmental impact.

Focused on

- Full loads
- Optimal milk runs
- Delivery condition-Free Carrier (FCA)
- Co-ordinated return transport
- Choice of transport mean
- Use lead logistic provider

Logistic assurance in new car programmes

FULL LOADS

- 100% trailer fill rate.
- Reduction of administration.
- No extra handling of pallets at transporter's terminal
- Potential transport cost reduction 20-50%.

Preconditions for suppliers on full load:

- AVIEXP or DESADV = 100%
- Daily Call-Offs
- *Daily/Dynamic* pick-up possibilities at supplier

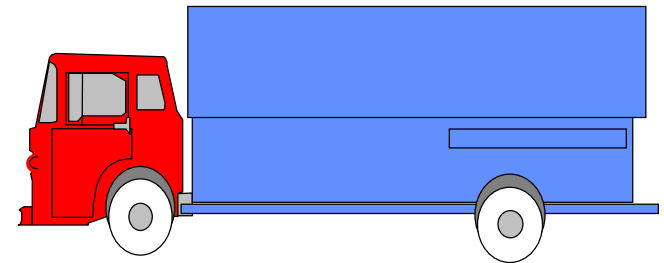

Logistic assurance in new car programmes

Packaging design

Standard packaging or typebound packaging ?

If typebound inhouse or outsourced packaging design ?

Inhouse is always chosen when the packaging has a high impact on the assembly process.

Logistic assurance in new car programmes

Virtual Verification

Adaptation to virtual
product development of
product and process

Ergonomics

Quality assurance during
Transport

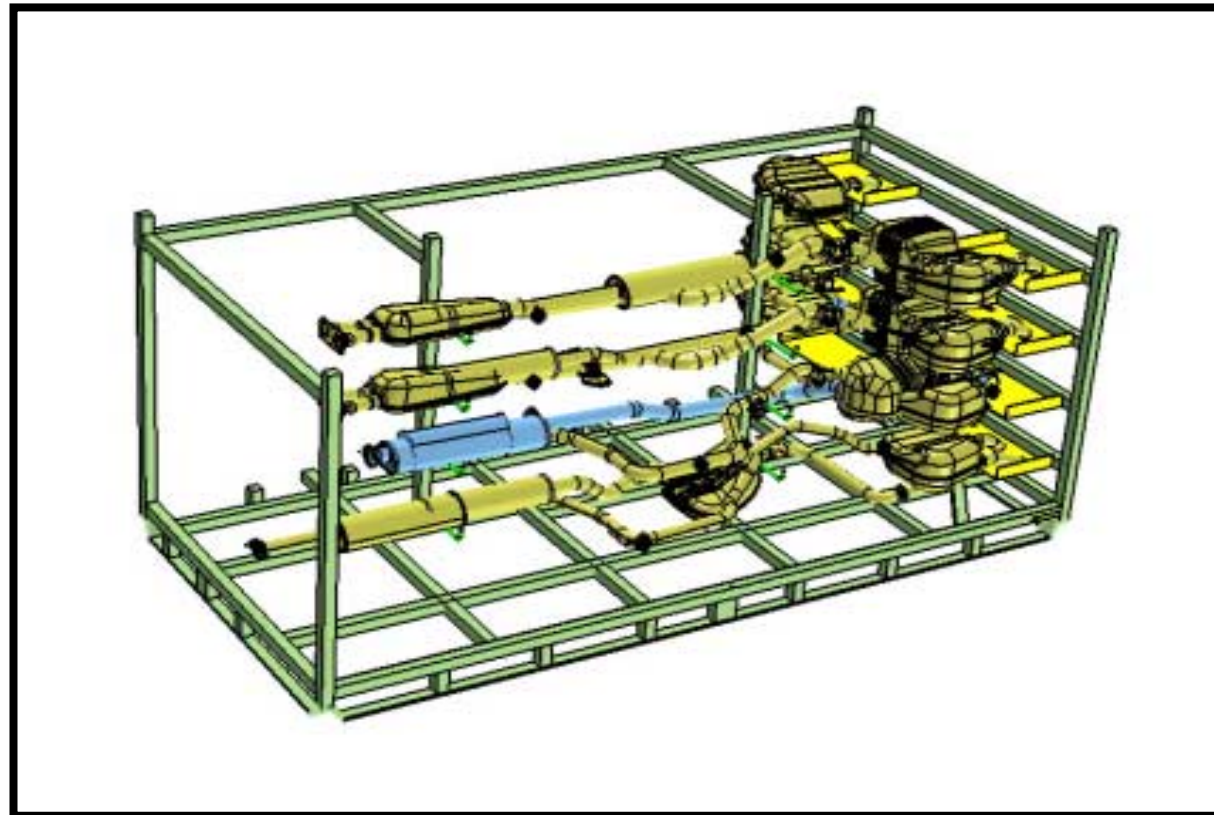

Logistic assurance in new car programmes

Logistic assurance activities

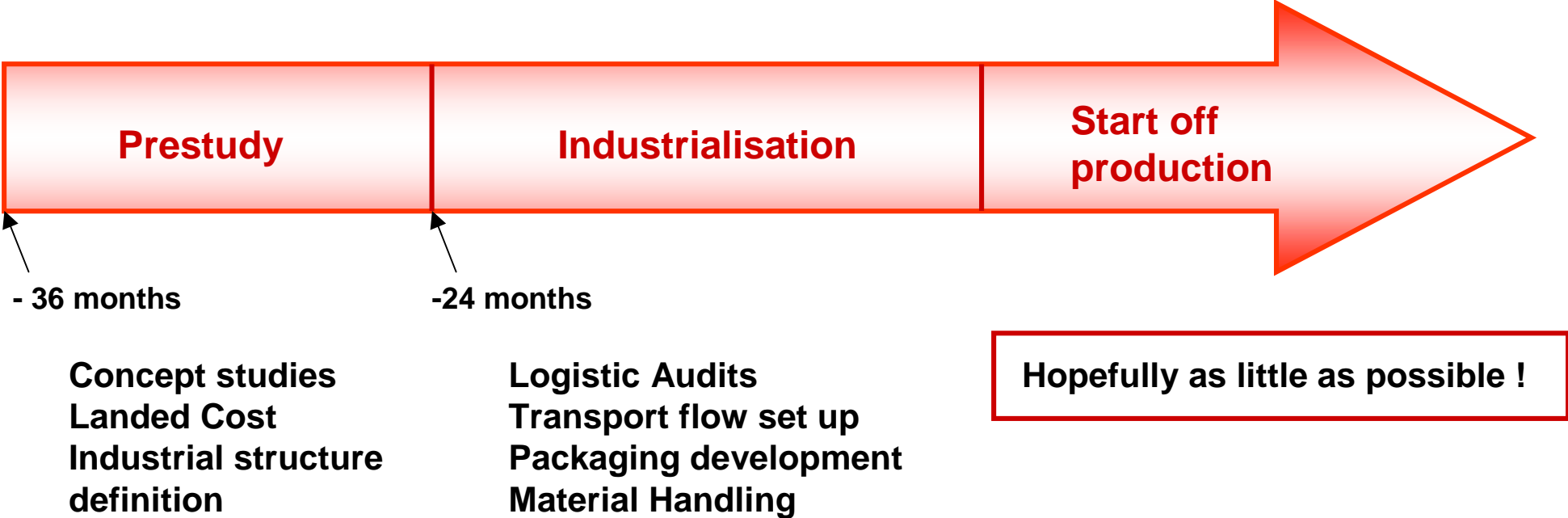

Logistic assurance in new car programmes

My message to you today :

- Focus on early involvement in new projects
- Dont wait to get invited, invite your self if needed
- Ensure that you have enough resources and rigid processes in early project stages

Logistic assurance in new car programmes

My message to you today :

REMEMBER : what you forget to do in early project phases you will have to do later at a higher cost with a higher time pressure and most likely with a worse result.