

# VOLVO

## Access management for Extranet Portals and connected Applications 2008-06-17



# Presentation Content

- How it used to work: Overview
- How it used to work: Problem Description
- Current situation: Overview
- Current situation: Problem Description
- To be situation: Overview
- To be situation:
- Conclusions
- Questions

# How it used to work

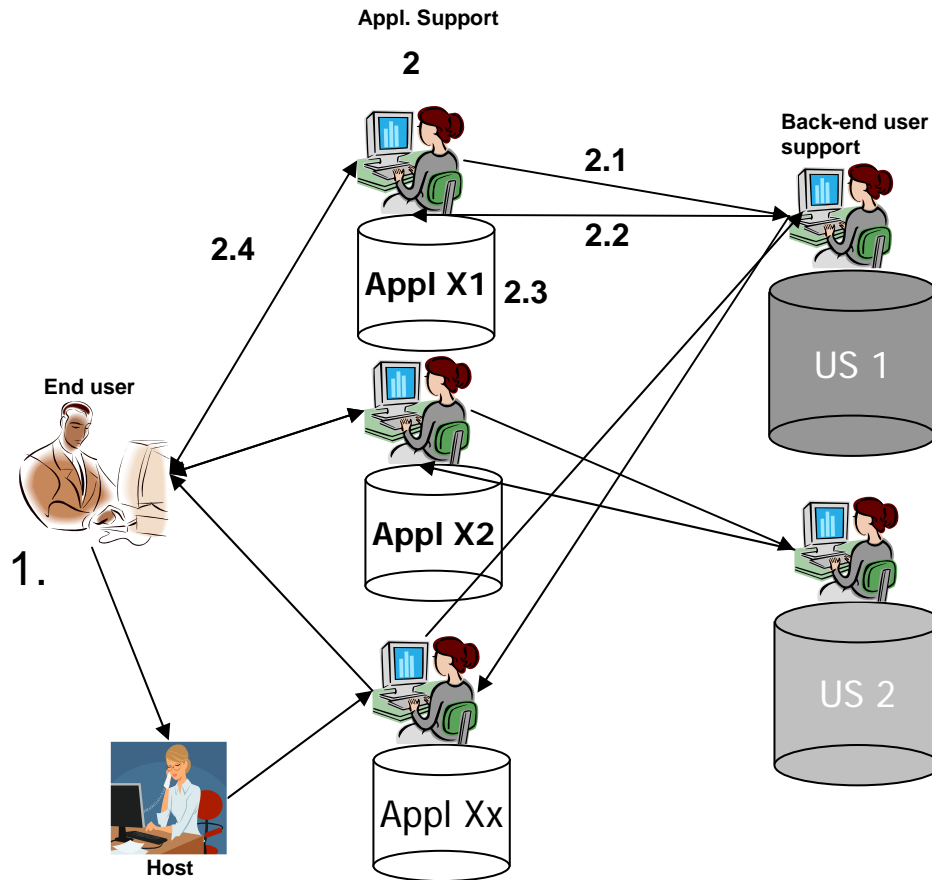

1. The external user request access through assigned processes. These differ depending on application and/or Business area within Volvo.
2. The Application support team get the request and initiate the steps of setting up the user.
  - 2.1** Request user id from UAS team. This is commonly done by sending an Excel sheet ones a day.
  - 2.2** The user get setup and is allocated a user ID. Information is then returned to the application team.
  - 2.3** The user get setup in the application
  - 2.4** User is given his access

Note: this cover the direct access to an application, no portal is involved here.  
If adding the Extranet portals to this complexity an other desk would be in the picture as shown in the next slide

# How it used to work :

## problem description

- Very time consuming for both end user and support
- Long implementation time
- Inability to create an effective support organization
  - Each application only support their own users
  - Confusing for the end user
  - No common processes
- Confusing for users with many different access points
- One user ID used by several users created additional support
- Application access bound to different solutions
- Many systems to update
- Different user stores & UA tools (Application access bound to different solutions)
- High cost for both Support and Systems (all setup handled inside Volvo)
- ...

# Current situation:

## Application access through Extranet portals

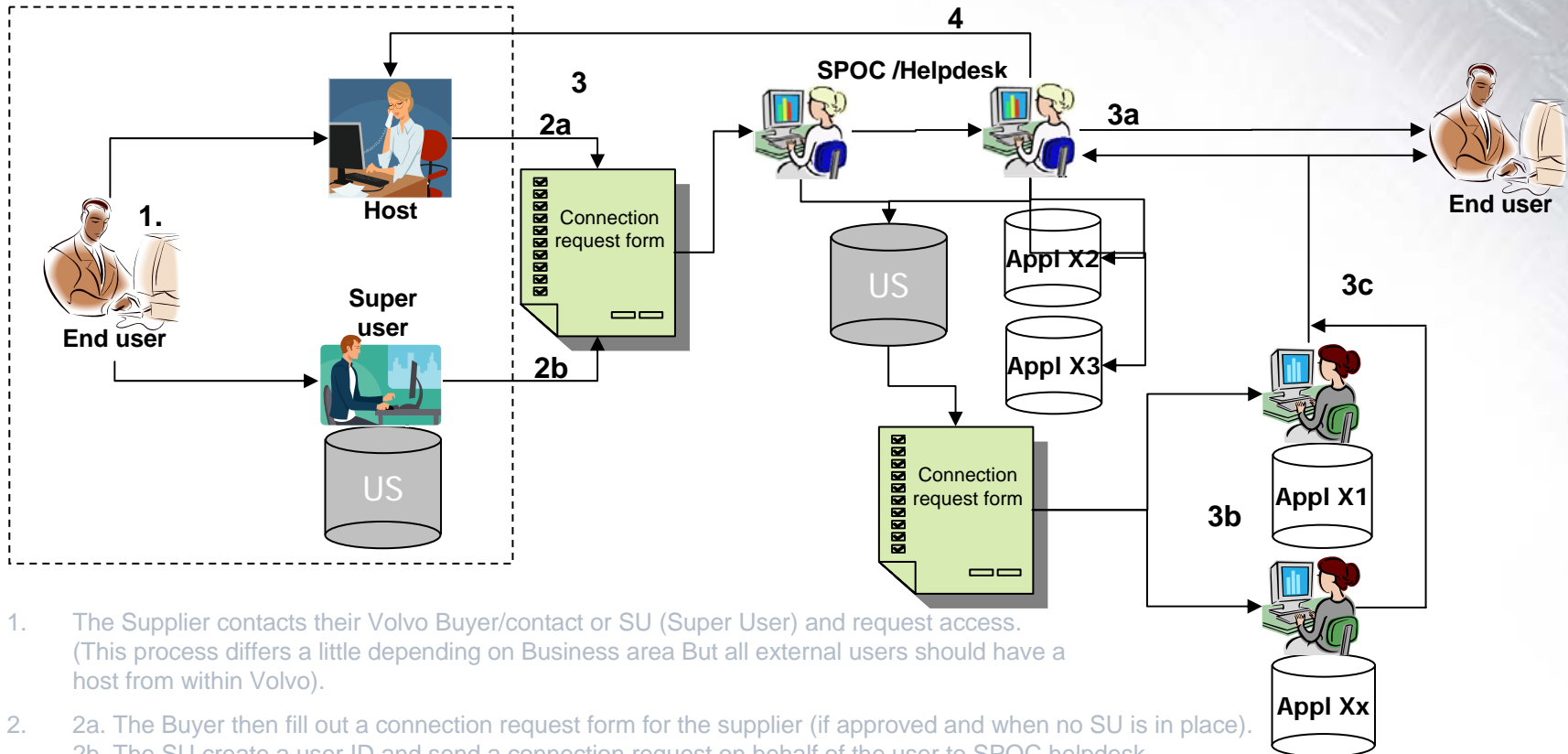

1. The Supplier contacts their Volvo Buyer/contact or SU (Super User) and request access. (This process differs a little depending on Business area But all external users should have a host from within Volvo).
2. 2a. The Buyer then fill out a connection request form for the supplier (if approved and when no SU is in place).  
2b. The SU create a user ID and send a connection request on behalf of the user to SPOC helpdesk.
3. SPOC review the request to se who needs to handle it. In some cases the SPOC can handle the whole request including the application setup (se 3a Below) in other the request is forwarded to the application team in question for handling (se 3b below). In any case the SPOC will create the user ID if the request comes from the Host.  
3a. SPOC team take the request, Create the user ID (If needed) and connect the user to the applications in question. Then the user and Host/SU is informed that the request has been completed.  
3b. The Base User setup has at this time been done so the application team set the user up in the application.  
3c. Inform the user and SPOC.
4. SPOC informs the Host/SU.

# Current situation:

## problem description

- Still some what time consuming
- Implementation time much better but still not good enough
- Complex support organization with many stake holders but processes are in place and working rather well.
- Still to many systems to update
- Still to high cost for Support and Systems
- Much higher demand on personal user ID's
- The Host needs to be informed on every user setup
- ...

# To be situation:

## How it is planned to work in 2009

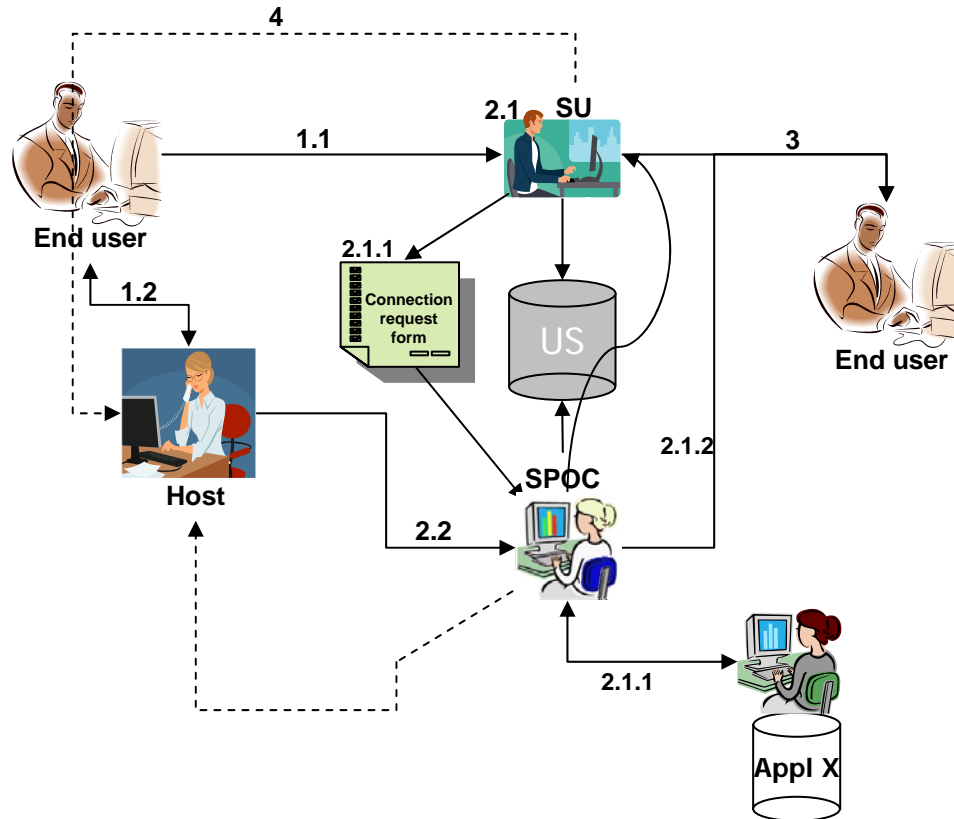

- The End user contact his:
  - SU
  - Host
 (The Host then check if the user have a SSU, if there is one he direct the user to him/her.)
- The SSU setup the user in the UAT (User Admin Tool) for both the portal and the applications in question.
    - In a few cases a connection request needs to be sent in for Applications that has to be controlled internally. This is sent through the SPOC.
    - The SPOC inform the SU ones the Application setup has been done.
  - The SPOC handle the request and forward any connection request (se 2.1.1) to the application support.
- The SSU / SPOC inform the end user ones done.
- The Host is informed that the user has been setup. How this will be implemented has not been decided yet though.

# Conclusions on “To Be Situation”:

This solution has several positive results such as:

End user organization:

- It saves time
  - The information is handled by the owner
  - Possibly faster response
  - Better security, the organization knows the business and who should/shouldn't have access and to what.
  - Will make it easier to work with Volvo.
- 
- Volvo:
  - It saves time on several instances
  - Get more accurate data (Enables new possibilities with the data being in one place)
  - Decreased cost
  - Enables new possibilities with the data being in one place
  - Increase the trust level between Volvo and their external Partners/Suppliers
  - ...



# Summation

As it was	As it works now	To be
<p><b>End user perspective:</b></p> <ul style="list-style-type: none"> <li>• Many different contacts to get what you need</li> <li>• Several user id's needed in some cases</li> <li>• Several ULR's to connect to, (different applications) some in early portals but most on unique URL's.</li> <li>• Different support teams to contact.</li> <li>• ...</li> </ul> <p><b>Volvo perspective:</b></p> <ul style="list-style-type: none"> <li>• Time consuming due to spread out user admin and ineffective handling</li> <li>• Much frustration from end users</li> <li>• Costly</li> <li>• Hard to support for the business &amp; IT</li> <li>• ...</li> </ul>	<p><b>End user perspective:</b></p> <ul style="list-style-type: none"> <li>• One way to request access. Either through their own SU or through a Host</li> <li>• One URL (Extranet) to reach the applications and information.</li> <li>• Sometimes still to long lead time to get a new ID.</li> <li>• Single point of contact for support.</li> <li>• ...</li> </ul> <p><b>Volvo Perspective:</b></p> <ul style="list-style-type: none"> <li>• Cost has been reduced</li> <li>• The support organizations are much more structured and effective</li> <li>• Happier end users due to easier access to support</li> </ul>	<p><b>End User perspective:</b></p> <ul style="list-style-type: none"> <li>• Self going on access to both Extranet portals and Applications.</li> <li>• Possibly faster to get access.</li> <li>• Better control on their organization in their business with Volvo.</li> <li>• Still access to SPOC</li> <li>• One portal one purpose. One URL</li> <li>• Less time consuming.</li> </ul> <p>Volvo Perspective:</p> <ul style="list-style-type: none"> <li>• Savings in both time and cost will increase.</li> <li>• More correct info on user and company data</li> <li>• Streamline support organizations</li> <li>• Tighter connection to the end users (Partners, Suppliers, Dealers ...) due to increased and better services.</li> </ul>

# Questions?